

Area	Lower [SQ FT M ²]	Upper [SQ FT M ²]	Total [SQ FT M ²]
Interior	1,846 171.4	1,576 146.4	3,422 317.9
Balcony	288 26.7	288 26.7	576 53.4
Garage	542 50.3		542 50.3
Total	2,676 248.4	4,252 394.9	

These drawings are conceptual only and are for the convenience of reference. They should not be relied upon as representations, express or implied, of the final detail of the residences. Units shown are examples of unit types and may not depict actual units. Stated square footages are ranges for a particular unit type and are measured to the exterior boundaries of the exterior walls and the centerline of interior finishing walls and in fact vary from the area that would be determined by using the description and definition of the "Unit" set forth in the Declaration (which generally only includes the interior spaces between the perimeter walls and excludes interior structural components). All depictions of appliances, plumbing fixtures, equipment, counters, sinks, floor coverings and other matters of detail are conceptual only and are not necessarily included in each Unit. Consult your Agreement and the Prospectus for the items included with the Unit. Dimensions and square footage are approximate, will vary with specific unit type, and may vary with actual construction. Additionally, measurements of rooms set forth on any floor plan are nominal and generally taken at the greatest points of each given room (as if the room were a perfect rectangle) without regard for any alcoves, unit orientation and windows (including number, size, orientation and wings), balcony/lanes (including configuration, size and railing/balustrade), structure and mechanical chases may vary. The developer expressly reserves the right to make modifications, revisions, and changes it deems desirable in its sole and absolute discretion and without notice.

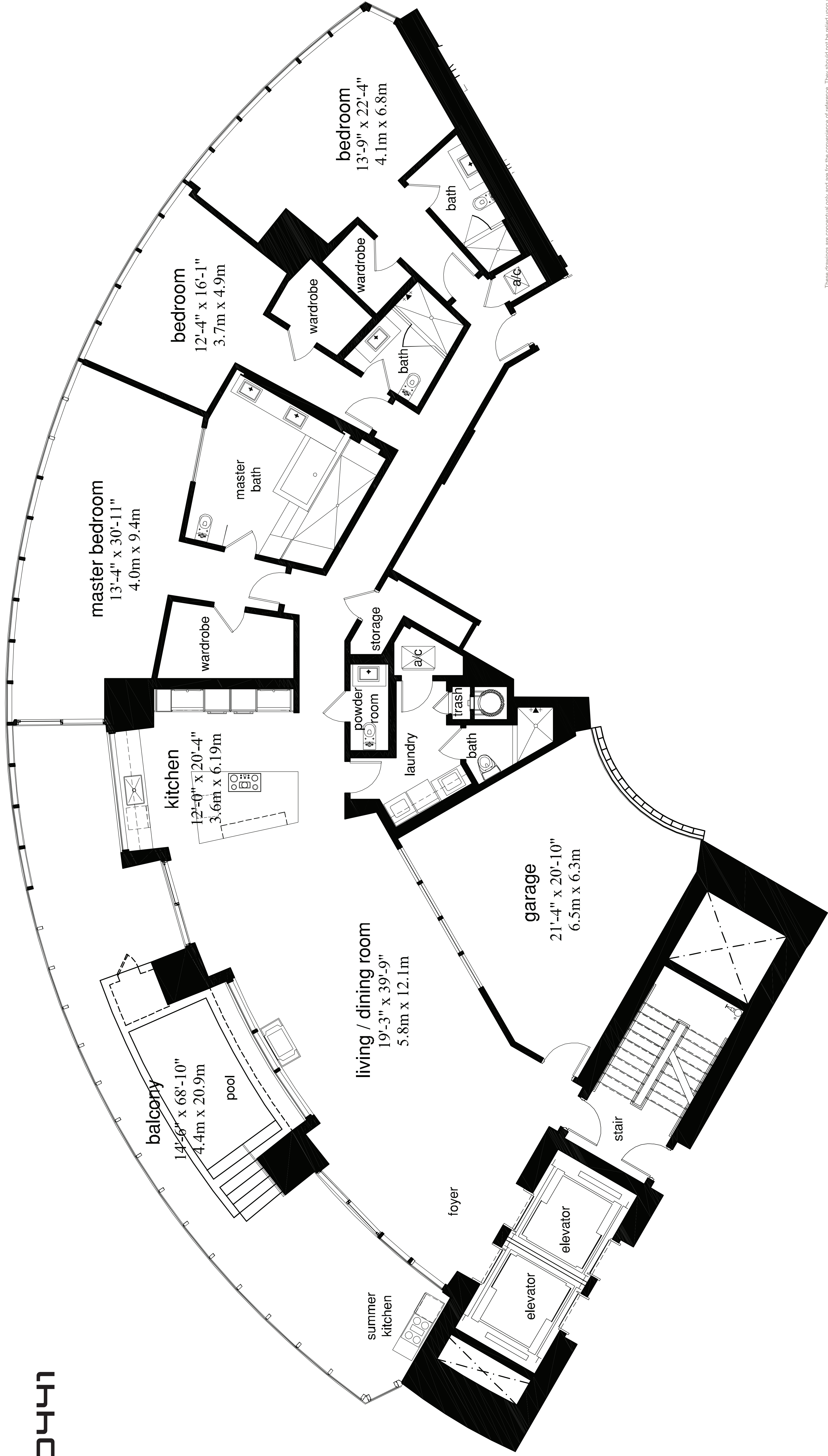
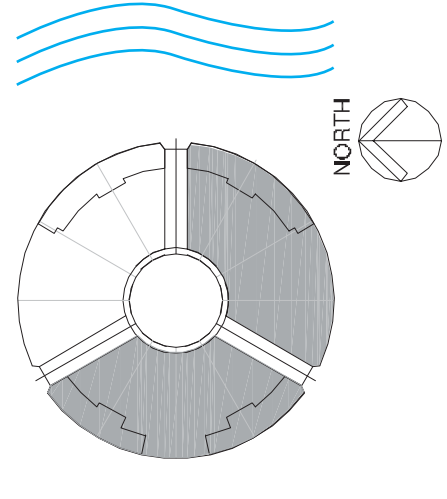

These drawings are conceptual only and are for the convenience of reference. They should not be relied upon as representations, express or implied, of the final detail of the residences. Units shown are examples of unit types and may not depict actual units. Stated dimensions are approximate and are based on the centerline of the unit. Dimensions are given in feet and inches and in meters. All dimensions are approximate and are based on the centerline of the unit. The floor area shown is for the interior of the unit and does not include the area of the exterior walls, balconies, terraces, or other areas that would be included in the calculation of the unit's area. The floor area shown is for the interior of the unit and does not include the area of the exterior walls, balconies, terraces, or other areas that would be included in the calculation of the unit's area. All depictions of appliances, plumbing fixtures, equipment, counters, soffits, floor coverings and other matters of detail are conceptual only and are not necessarily included in each Unit. Consult your Agreement and the Prospectus for the items included with the Unit. Dimensions and square footage are approximate, will vary with specific unit type, and may vary with actual construction. Additionally, measurements of rooms set forth on any floor plan are nominal and generally taken at the greatest points of each given room (as if the room were a perfect rectangle), without regard for any cutouts. Unit orientation and windows (including number, size, orientation and awnings), balcony/lanais (including configuration, size and railing/balustrade), structure and mechanical chases may vary. The developer expressly reserves the right to make modifications, revisions, and changes it deems desirable in its sole and absolute discretion and without notice.

Area	SQ FT	M ²
Interior	3,415	317.2
Balcony	831	77.2
Garage	503	46.7
Total	4,749	441.1

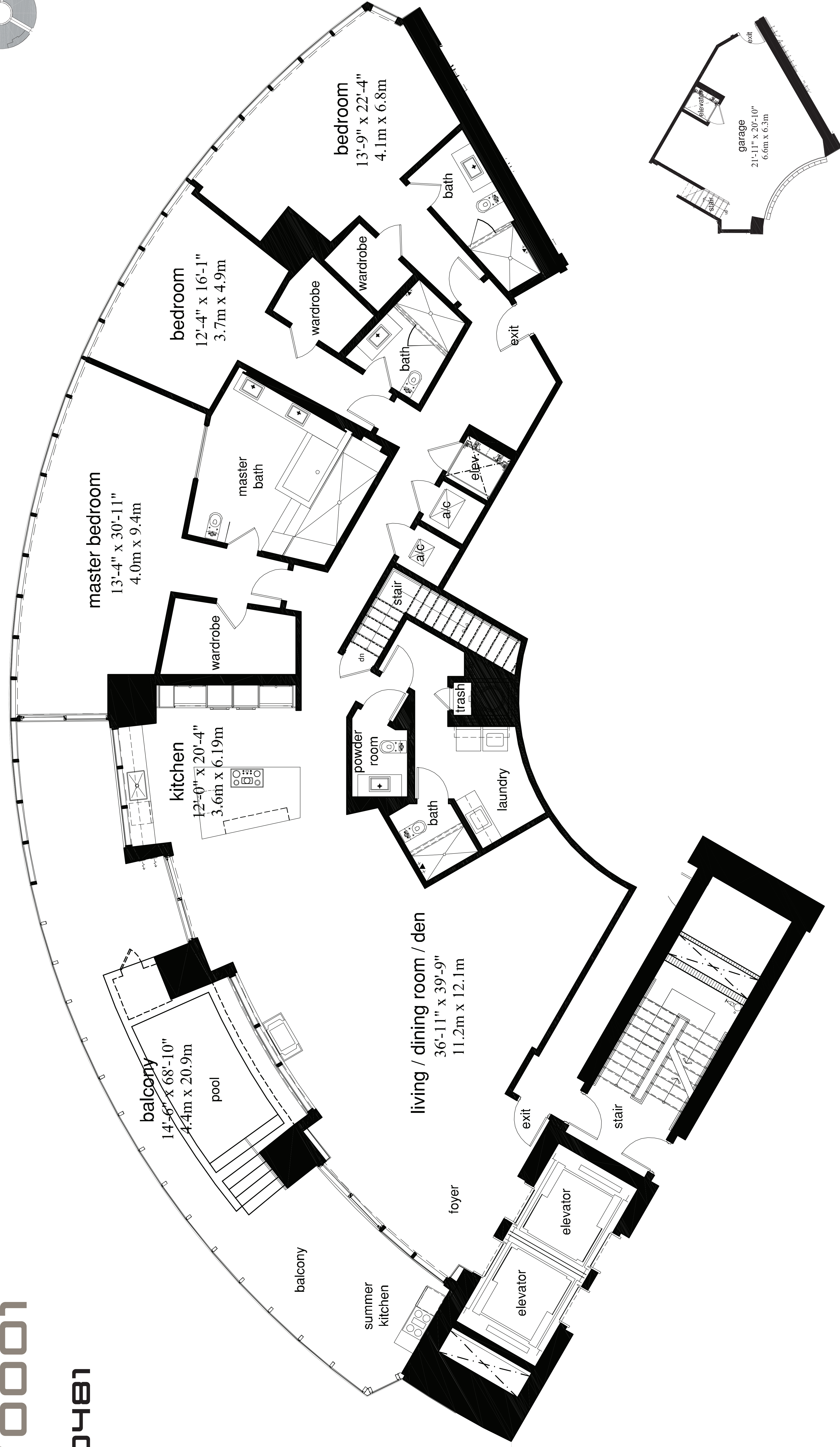
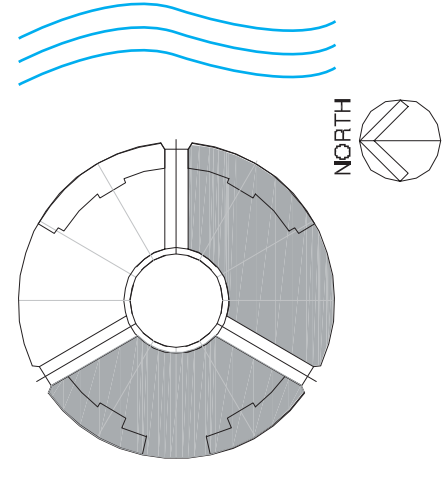

Area	SQ FT	M ²
Interior	3,785	351.6
Balcony	831	77.2
Garage	569	52.8
Total	5,185	481.6

These drawings are conceptual only and are for the convenience of reference. They should not be relied upon as representations, express or implied, of the final detail of the residences. Units shown are examples of unit types and may not depict actual units. Stated square footages are approximate and are based on the exterior measurements of the units. The actual square footages of the units as constructed may vary from those shown on these drawings. The developer reserves the right to make modifications, revisions, and changes it deems desirable in its sole and absolute discretion and without notice.

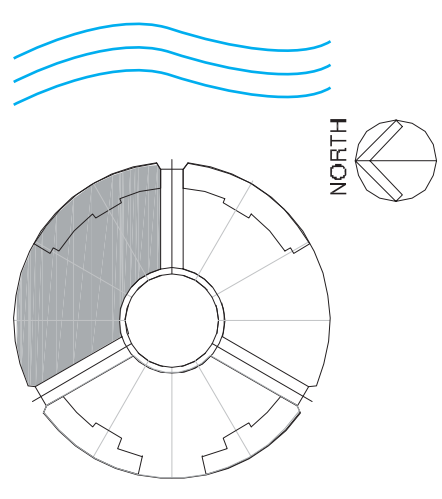

P'0550

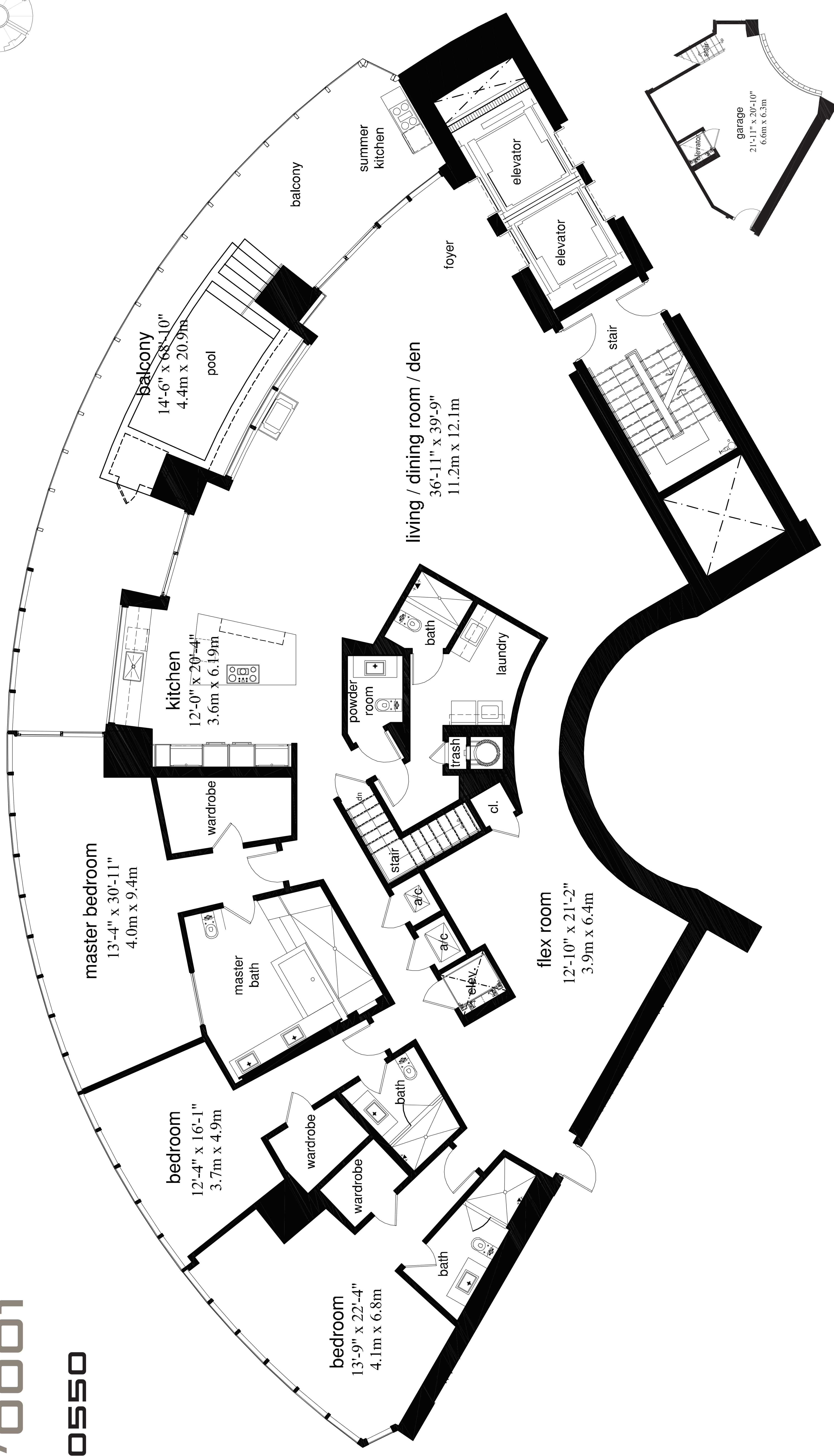

Area	SQ FT	M ²
Interior	4,513	419.2
Balcony	831	77.2
Garage	569	52.8
Total	5,913	549.2

These drawings are conceptual only and are for the convenience of reference. They should not be relied upon as representations, express or implied, of the final detail of the residences. Units shown are examples of unit types and may not depict actual units. Stated square footages are approximate and are based on the exterior walls of the units. Actual square footages may vary. Dimensions are shown in feet and inches and meters. All dimensions are approximate and are based on the exterior walls of the units. The developer expressly reserves the right to make modifications, revisions, and changes it deems desirable in its sole and absolute discretion and without notice.

P'0880 [LOWER]

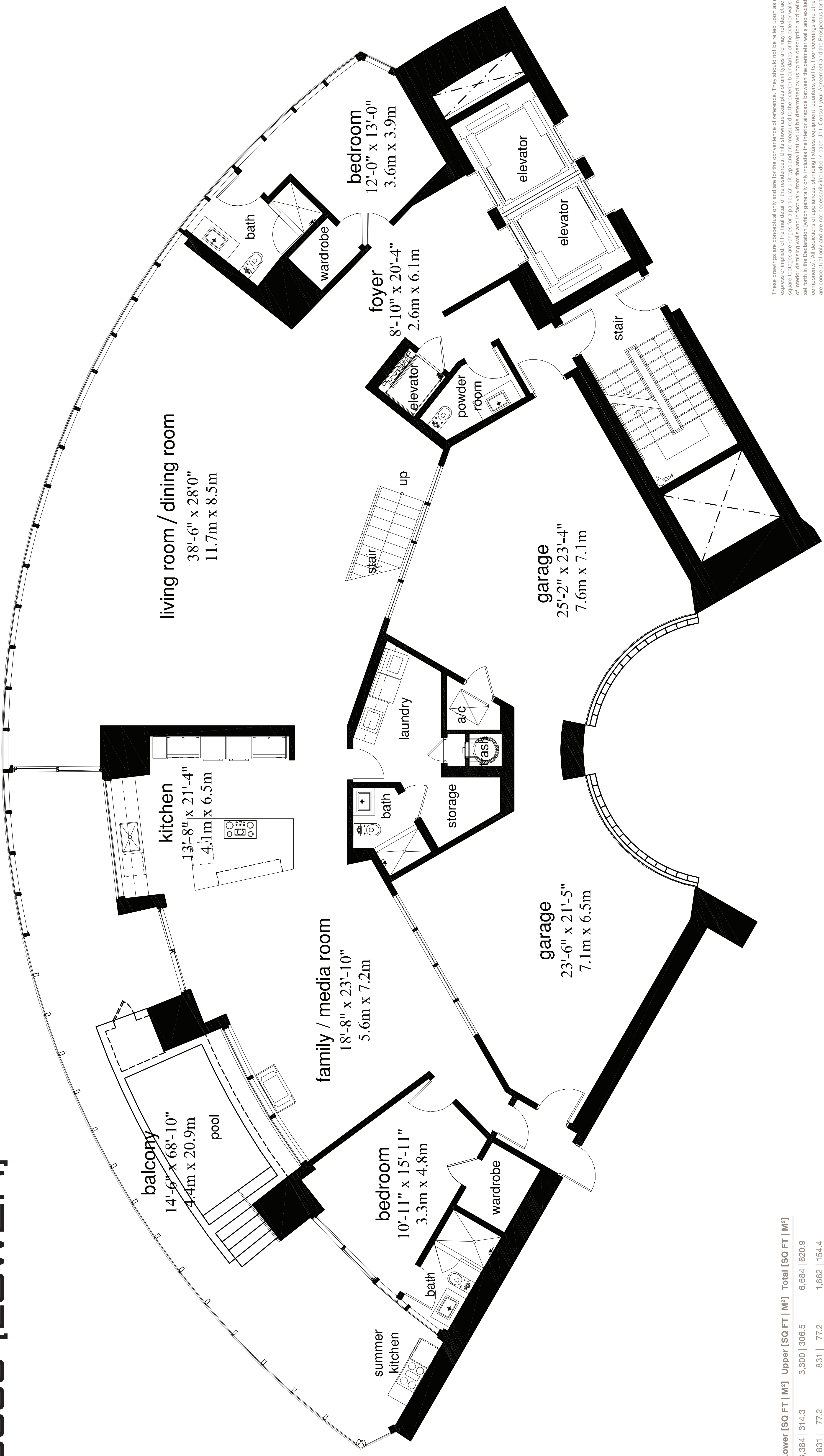
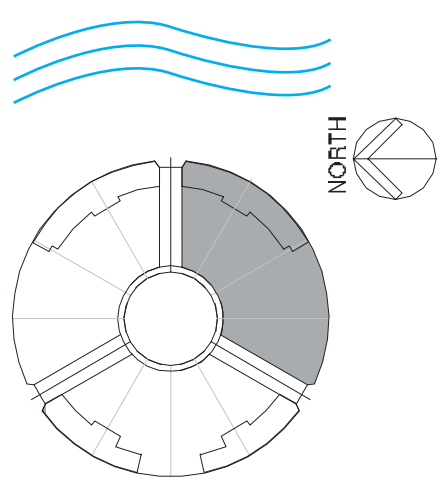

These drawings are conceptual only and are for the convenience of reference. They should not be relied upon as representations, express or implied, of the final detail of the residences. Units shown are examples of unit types and may not depict actual units. Stated area measurements are for the interior of the unit and are not intended to represent the total area of the unit. Measurements of floor area are based on the finished floor surface and do not include the area of the walls, ceiling, or floor. Measurements of perimeter are based on the exterior walls and do not include the area of the unit. Measurements of height are based on the finished floor surface and do not include the height of the ceiling or the height of the unit. Measurements of volume are based on the finished floor surface and do not include the volume of the walls, ceiling, or floor. Measurements of weight are based on the finished floor surface and do not include the weight of the unit. Measurements of length are based on the finished floor surface and do not include the length of the unit. Measurements of width are based on the finished floor surface and do not include the width of the unit. Measurements of depth are based on the finished floor surface and do not include the depth of the unit. Measurements of area are based on the finished floor surface and do not include the area of the walls, ceiling, or floor. Measurements of volume are based on the finished floor surface and do not include the volume of the walls, ceiling, or floor. Measurements of weight are based on the finished floor surface and do not include the weight of the unit. Measurements of length are based on the finished floor surface and do not include the length of the unit. Measurements of width are based on the finished floor surface and do not include the width of the unit. Measurements of depth are based on the finished floor surface and do not include the depth of the unit. Measurements of area are based on the finished floor surface and do not include the area of the walls, ceiling, or floor. Measurements of volume are based on the finished floor surface and do not include the volume of the walls, ceiling, or floor. Measurements of weight are based on the finished floor surface and do not include the weight of the unit.

Area	Lower [SQ FT M ²]	Upper [SQ FT M ²]	Total [SQ FT M ²]
Interior	3,384 314.3	3,300 306.5	6,684 620.9
Balcony	831 77.2	831 77.2	1,662 154.4
Garage	1,128 104.8		1,128 104.8
Total	5,343 496.3	4,131 383.7	9,474 880.1

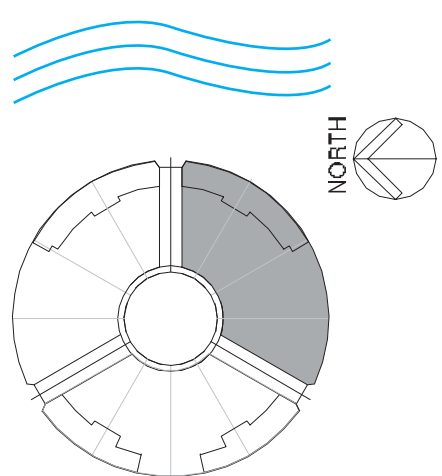

P'0880 [UPPER]

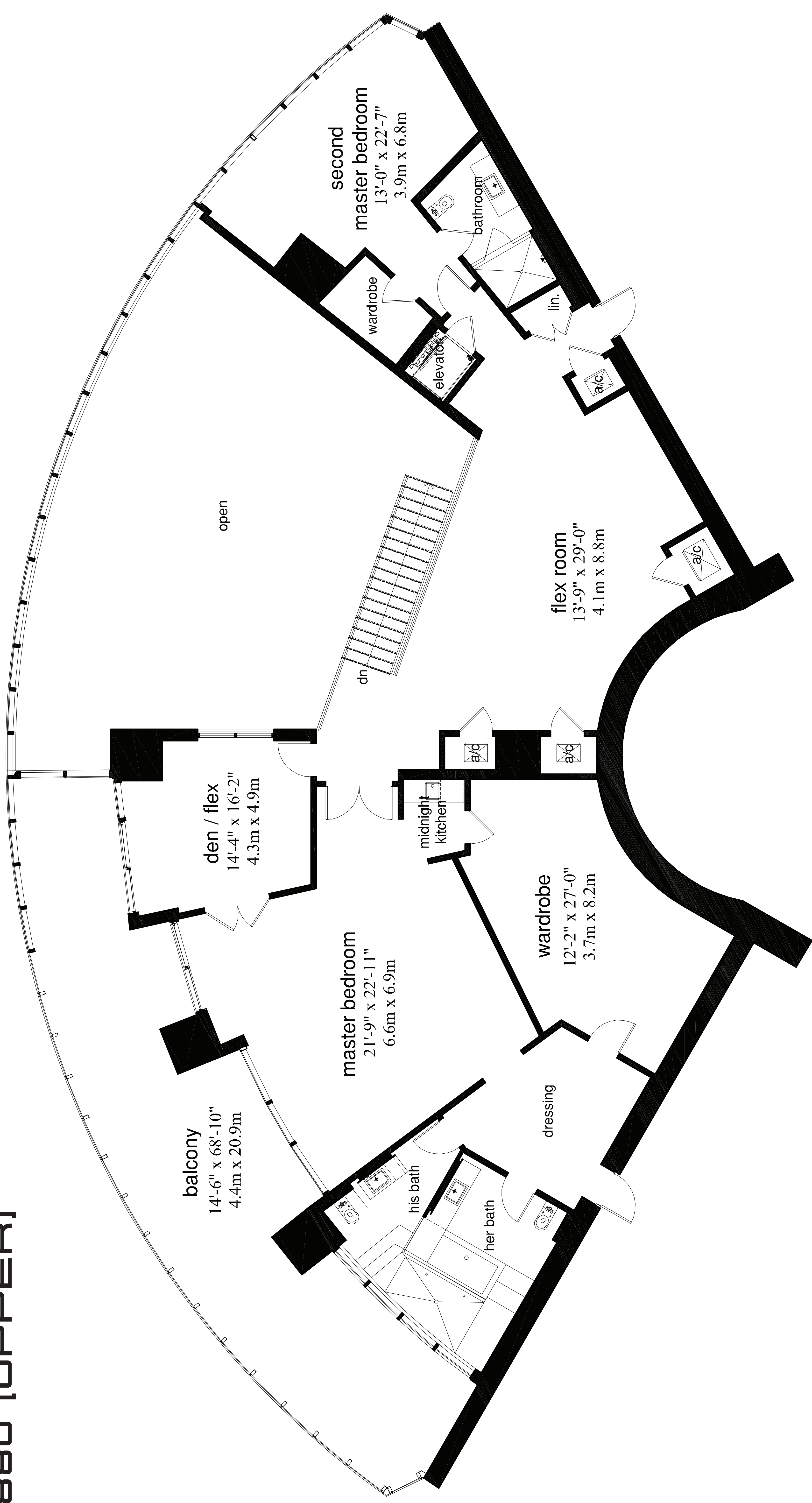

These drawings are conceptual only and are for the convenience of reference. They should not be relied upon as representations, express or implied, of the final detail of the residences. Units shown are examples of unit types and may not depict actual units. Stated floor areas are approximate and are based on a particular unit type and are not intended to represent the actual floor area of any unit. All dimensions are shown in feet and inches and meters. Dimensions are approximate and are based on the exterior walls and include the perimeter walls and excludes interior structural components. All depictions of appliances, plumbing fixtures, equipment, counters, soffits, floor coverings and other matters of detail are conceptual only and are not necessarily included in each Unit. Consult your Agreement and the Prospectus for the items included with the Unit. Dimensions and square footage are approximate, will vary with specific unit type, and may vary with actual construction. Additionally, measurements of rooms set forth on any floor plan are nominal and generally taken at the greatest points of each given room (as if the room were a perfect rectangle), without regard for any cutouts. Unit orientation and windows (including number, size, orientation and awnings), balcony/lanais (including configuration, size and railing/balustrade), structure and mechanical chases may vary. The developer expressly reserves the right to make modifications, revisions, and changes it deems desirable in its sole and absolute discretion and without notice.

Area	Lower [SQ FT M ²]	Upper [SQ FT M ²]	Total [SQ FT M ²]
Interior	3,384 314.3	3,300 306.5	6,684 620.9
Balcony	831 77.2	831 77.2	1,662 154.4
Garage	1,128 104.8		1,128 104.8
Total	5,343 496.3	4,131 383.7	9,474 880.1